

Satel

Radio Modems

For Use With

Differential Corrections



Satel User Manual

Confidently. Accurately.

Legal Notice

Information furnished is believed to be accurate and reliable. However, Oxford Technical Solutions Limited assumes no responsibility for the consequences of use of such information nor for any infringement of patents or other rights of third parties which may result from its use. No license is granted by implication or otherwise under any patent or patent rights of Oxford Technical Solutions Limited. Specifications mentioned in this publication are subject to change without notice and do not represent a commitment on the part of Oxford Technical Solutions Limited. This publication supersedes and replaces all information previously supplied. Oxford Technical Solutions Limited products are not authorised for use as critical components in life support devices or systems without express written approval of Oxford Technical Solutions Limited.

All brand names are trademarks of their respective holders.

Copyright Notice

© Copyright 2009, Oxford Technical Solutions.

Revision

Document Revision: 091007 (*See Revision History for detailed information*).

Contact Details

Oxford Technical Solutions Limited
77 Heyford Park
Upper Heyford
Oxfordshire
OX25 5HD

Tel: +44 (0) 1869 238 015

Fax: +44 (0) 1869 238 016

<http://www.oxts.co.uk>
<mailto:info@oxts.co.uk>

Table of Contents

Introduction	4
Components	4
Connections	5
Radio Modem Settings	8
Operation	9
Interference Check	9

Introduction

This document describes the recommended configuration for the SATEL SATELLINE-3ASd radio modems. These radio modems may be supplied as part of an RT3000 system that includes a base-station. The settings for the base-station radio modem and for the vehicle radio modem are nearly identical, only differing in their TX and RX priority setting.

The SATELLINE-3ASd includes a display and buttons so that the configuration can be changed. The radio modems come configured correctly, this document is only required if the configurations have been changed and need to be restored.

Components

The SATELLINE-3ASd system includes two components, the aerial and the radio modem. These are shown in Figure 1 below.

Figure 1. SATELLINE-3ASd and Antenna



Connections

The connection diagrams for the radio modems are shown in the figures below.

Figure 2. GPS-Base Connections for Radio Modem

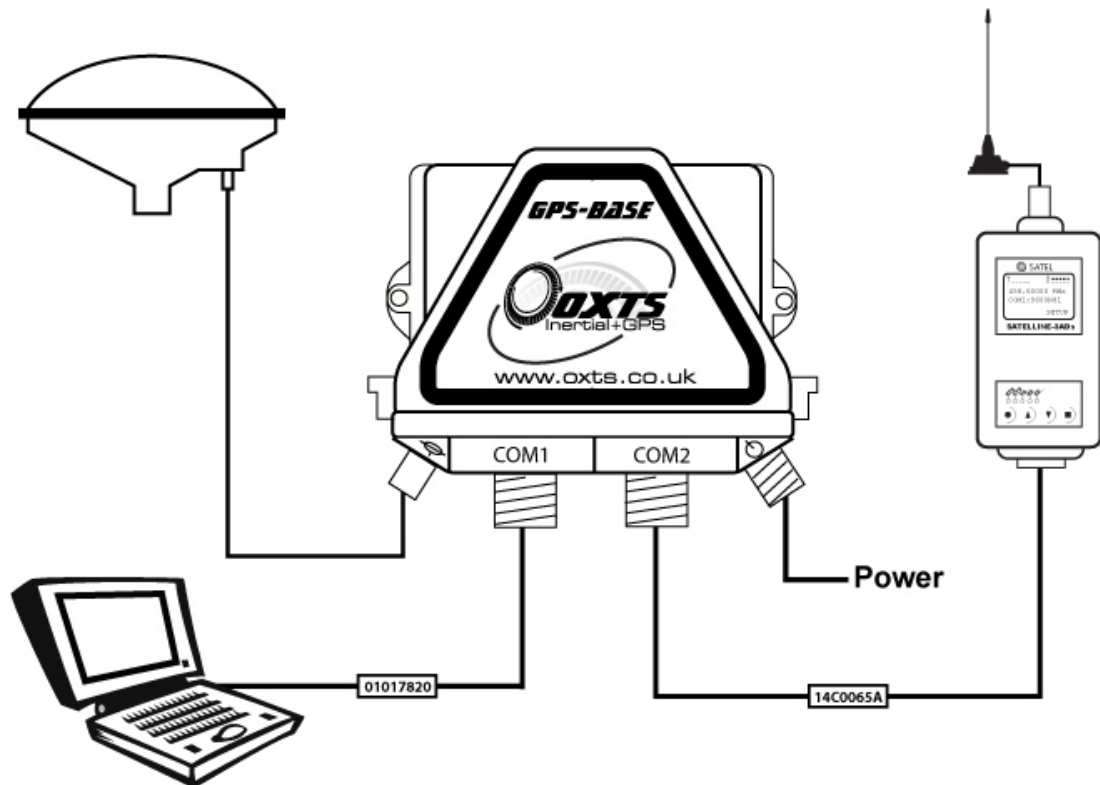

Note: Earlier GPS-Base systems may have been shipped with a combined power and radio user cable 14C0052B in place of the separate power cable and radio cable 14C0065A.

Figure 3. RT-Base Connections for Radio Modem

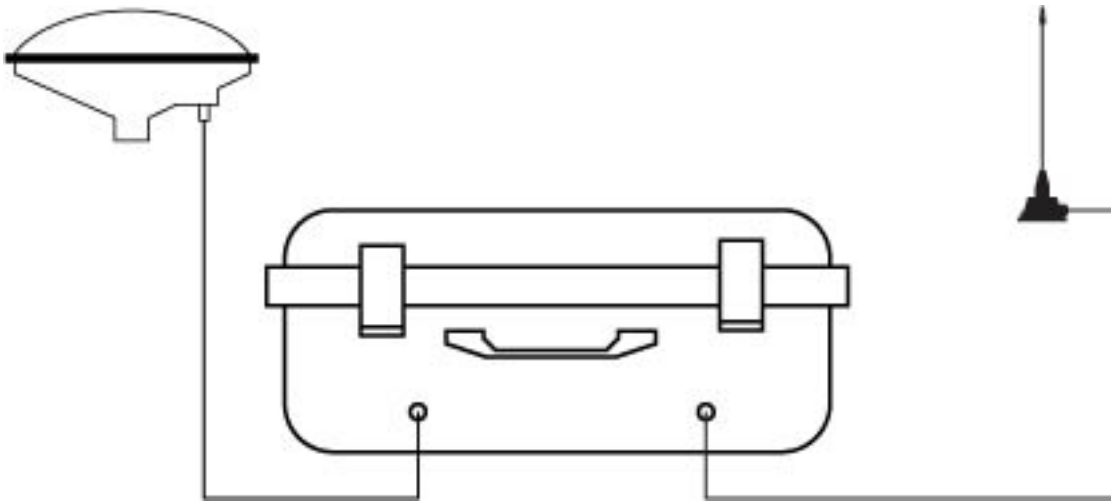
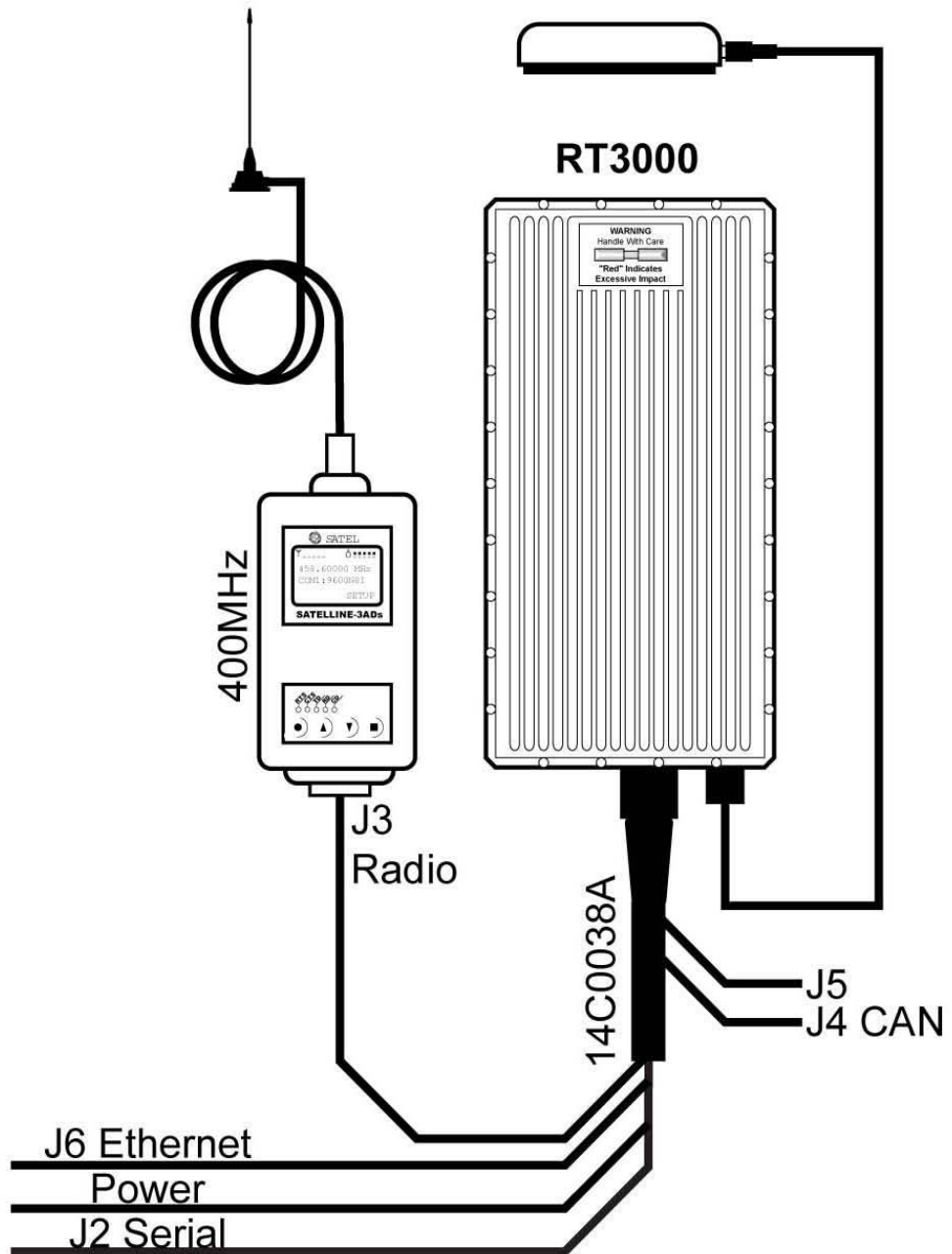

Figure 4. Mobile Connections for Radio Modem



Radio Modem Settings

Only the settings for normal operation are described here. Refer to the SATELLINE-3ASd manual for details how to operate the radio modems.

Table 1. SATELLINE-3ASd Settings

Menu	Sub-Menu	Setting
	RF Frequency	458.6000 MHz, see note 1 below.
Radio Settings	TX Level Sig. Threshold TX start delay	See note 2 below -112dBm 0ms
Addressing	RX addr TX addr RX addr -> RS TX add auto	OFF OFF OFF OFF
Port1		ON 9600 bit/s 8 bit data None parity 1 stop bit
Port2		OFF
Handshaking	CTS CD RTS	Clr to send RSSI Ignored
Additional	Error corr. Error check Repeater SL-commands Priority	ON ON OFF OFF Base-station: TX Mobile: RX

Note 1. Select a spare frequency that is not being used in your area. Both radio modems must be set to the same frequency, this frequency is used as the default.

Note 2. You can set the “TX Level” for the maximum allowed in your country. In the UK the maximum setting is 500mW. The SATELLINE-3ASd will allow up to 1000mW output power.

Operation

When operating the radio modems it is sensible to check that the signal is being transmitted correctly and received correctly and that there is no interference on the RF Frequency used.

The table below gives some combinations of the LEDs and describes their significance.

Table 2. LED States and meanings

LEDS					Description
RTS	CTS	TD	RD	CD	
Off	Red	Off	Off	Off	Idle
Off	Red	Red	Off	Red	Transmitting a packet
Off	Red	Off	Off	Orange	Noise or other transmission on this frequency
Off	Red	Off	Green	Green	Receiving a packet

Interference Check

To check for interference look at the CD LED on the radio modems. With the base-station off (or disconnected), the mobile radio modem should not show Orange or Green. If either of these two colours are shown then there is another user on this frequency. Select a different frequency.