

RT-Strut

Mounting
Pole



User Manual

Confidently. Accurately.

Legal Notice

Information furnished is believed to be accurate and reliable. However, Oxford Technical Solutions Limited assumes no responsibility for the consequences of use of such information nor for any infringement of patents or other rights of third parties which may result from its use. No license is granted by implication or otherwise under any patent or patent rights of Oxford Technical Solutions Limited. Specifications mentioned in this publication are subject to change without notice and do not represent a commitment on the part of Oxford Technical Solutions Limited. This publication supersedes and replaces all information previously supplied. Oxford Technical Solutions Limited products are not authorised for use as critical components in life support devices or systems without express written approval of Oxford Technical Solutions Limited.

All brand names are trademarks of their respective holders.

Copyright Notice

© Copyright 2018, Oxford Technical Solutions.

Revision

Document Revision: 180510

Contact Details

Oxford Technical Solutions Limited
77 Heyford Park
Upper Heyford
Oxfordshire
OX25 5HD
United Kingdom

Tel: +44 (0)1869 814 253
Fax: +44 (0)1869 251 764

Web: <http://www.oxts.com>
Email: support@oxts.com

Warranty

Oxford Technical Solutions Limited warrants the RT-Strut product to be free of defects in materials and workmanship, subject to the conditions set forth below, for a period of one year from the Date of Sale.

‘Date of Sale’ shall mean the date of the Oxford Technical Solutions Limited invoice issued on delivery of the product. The responsibility of Oxford Technical Solutions Limited in respect of this warranty is limited solely to product replacement or product repair at an authorised location only. Determination of replacement or repair will be made by Oxford Technical Solutions Limited personnel or by personnel expressly authorised by Oxford Technical Solutions Limited for this purpose.

In no event will Oxford Technical Solutions Limited be liable for any indirect, incidental, special or consequential damages whether through tort, contract or otherwise. This warranty is expressly in lieu of all other warranties, expressed or implied, including without limitation the implied warranties of merchantability or fitness for a particular purpose. The foregoing states the entire liability of Oxford Technical Solutions Limited with respect to the products herein.

Safety notice

A recent risk assessment highlighted concerns that, when mounted inside the cockpit of the vehicle, the OxTS RT-Strut mounting pole could come loose in specific situations, for example after a vehicle impact with consequential rapid deceleration, or an impact that caused roof or floor deformation. We would recommend that where possible existing RT-Struts should be mounted in an area separated from the driver/passenger compartment such as the boot (trunk) of the vehicle.

You must inform your RT-Strut users of the safety concern and make them aware that we recommend that they include this information in their risk assessments.

We are looking to change the design of the RT-Strut mounting pole to mitigate the risk in the future and also at a solution that our customers will be able to retrofit to existing RT-Struts.

Table of contents

Introduction	6
Scope of delivery	7
Specification	8
Installation	9
Configuration	12
Revision history	13

Introduction

The RT-Strut is a fast car mounting system for the Inertial and GNSS navigation family of OxTS products. This includes the RT1003, RT2000, RT3000 and RT4000 series, the Inertial+, Survey+ and the xNAV. The RT1003 and xNAV require additional mounting brackets, sold separately. Using the RT-Strut the OxTS Inertial Navigation Systems (INS) can be mounted securely in most vehicles in minutes.

The RT-Strut wedges between the floor and the roof of the car, normally in front of the back seat and across the transmission tunnel. A built-in spring provides the necessary force required to keep the RT-Strut in place. A lever is used to release and engage the spring. Wide feet at the bottom of the RT-Strut ensure excellent yaw rigidity.

The RT-Strut uses a carbon fibre pole for an extremely stiff yet lightweight design.

Figure 1. RT-Strut mounted in a car



Scope of delivery

Table 1 lists all the items that are delivered with each RT-Strut.

Table 1. Summary of the RT-Strut components

Qty	Description
1	RT-Strut main body
2	RT-Strut extension legs
2	RT mounting brackets
2	RT-Strut clamps
5	M8×110 carriage bolts (1 spare)
9	M8 washer (1 spare)
9	M8 wing nuts (1 spare)
5	M4×16 RT screws (1 spare)
5	M4 washers (1 spare)
1	3 mm Allen key
1	RT-Strut bag

Figure 2. RT-Strut components

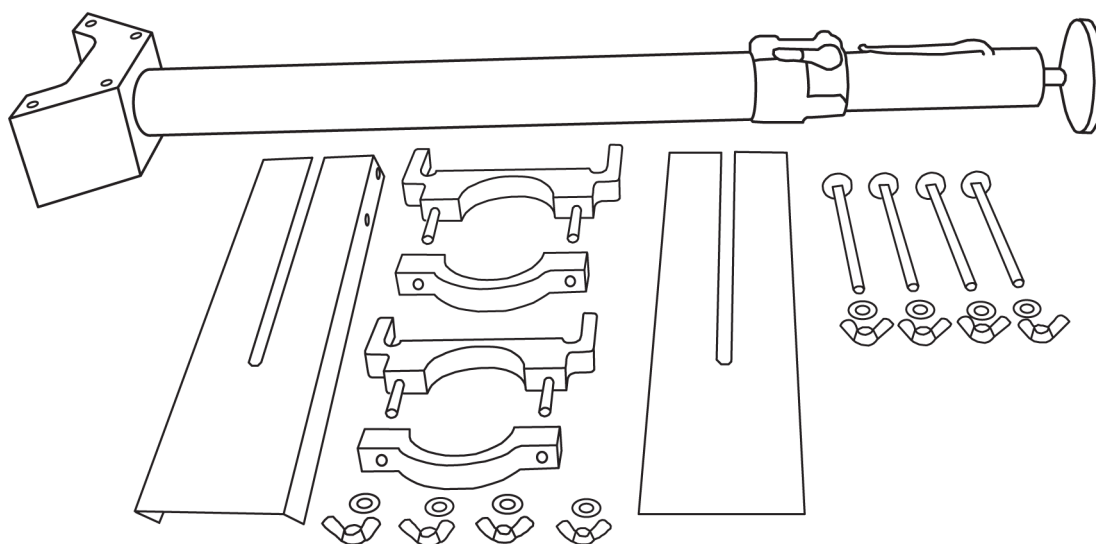

Specification

The technical specification of the RT-Strut unit is shown in Table 2.

Table 2. Technical Specification

Parameter	Specification Normal version	Specification Extended version
Weight	3.7 kg (including extension feet)	5.5 kg (including extension feet)
Maximum extension	1.50 m	2.40 m
Minimum extension	1.05 m (using extension feet) 0.81 m (excluding extension feet)	1.60 m (using extension feet) 1.30 m (excluding extension feet)
Temperature range	-10° to +70°C	-10° to +70°C

Installation

It is best to fit the INS to the RT-Strut after the RT-Strut is mounted in the vehicle. Although the OXTS INSs are robust systems, high shocks such as dropping or impacts against metal objects may cause damage.

The extension legs have some edges that may be sharp. These help the legs to grip the carpet. Take care not to injure yourself on the sharp edges.

Fit the extension legs to the base of the RT-Strut using the M8×110 carriage bolts provided, see Figure 3. Fit the M8 washers and M8 wing nuts to the carriage bolts and tighten. The carriage bolts have a square section at the top so that they cannot rotate when the wing nut is tightened.

Figure 3. RT-Strut attaching the extension legs

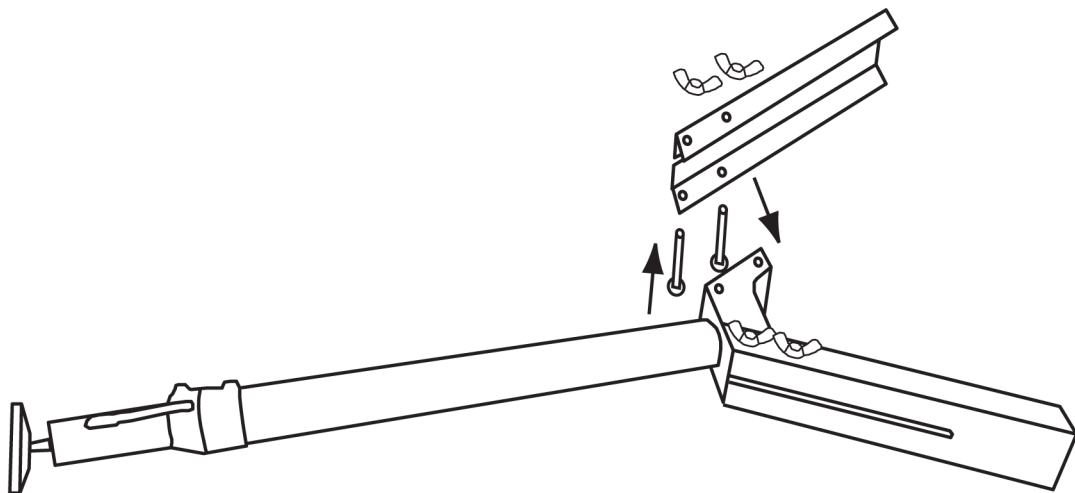

It is possible to use the RT-Strut without fitting the extension legs. However, the extension legs provide additional yaw stiffness; if slip angle or yaw rate is important then the extension legs should be used.

To install the RT-Strut:

1. Open black clamping lever on the carbon fibre pole and push the pole down to its minimum height.
2. Fit the RT-Strut inside the car and open the silver lever at the top to compress the spring.

3. Extend the pole up until it presses firmly against the roof of the car, then close the black clamping lever on the pole. Release the silver lever carefully, minding your fingers, to allow the spring to push on the roof.
4. Check the RT-Strut is securely mounted by attempting to move it. Ensure the upper pole is not able to slide down the pole when reasonable force is applied.

Occasionally, the clamping force of the black locking lever may need adjusting. To adjust the clamping force:

1. Release the black clamp and tighten the nut on the back of the clamp. Look for the +/- arrows on the nut. Turning it towards the + sign will tighten the catch and prevent the upper pole from becoming loose and sliding down.
2. If the upper pole is still able to slide down, release the clamp and tighten further. Repeat this process using small increments to prevent overtightening and damaging the Strut. Please note this is a left-hand thread and there are tightening arrows on the nut.

Next fit the RT mounting brackets on to the INS, see Figure 4.

Figure 4. Fitting RT mounting brackets to the INS

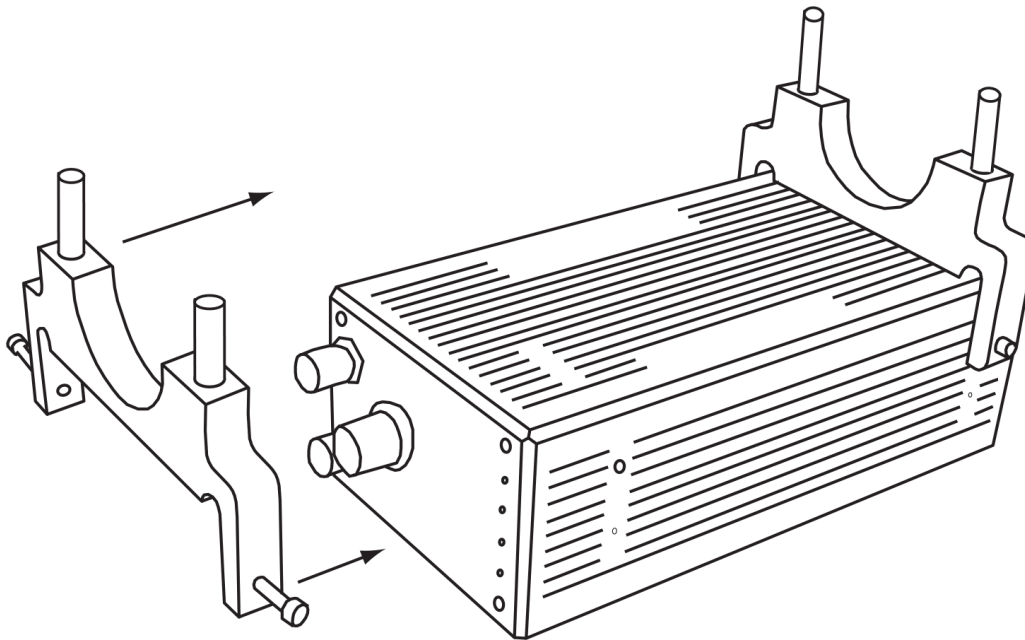

Fit the RT mounting brackets to the pole.

Although the carbon fibre pole is very stiff, mounting the INS as low as possible minimizes the accelerations caused by any bending of the pole.

Fit the INS and mounting brackets to the pole using the RT-Strut clamps, the M8 washers and the M8 wing nuts provided, see Figure 5. The default orientation when using the RT-Strut is to have the main connector of the INS facing up and the top of the unit facing the rear of the vehicle. In the default orientation the x -axis points down, the y -axis point left and the z -axis points forwards in the vehicle. Align the INS in the vehicle as accurately as possible to minimise slip angle offsets.

Figure 5. Attaching the INS to the RT-Strut

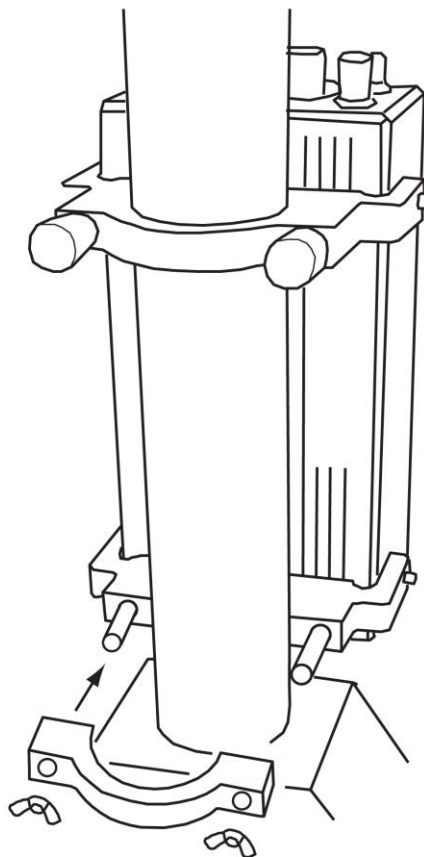

Finally, tighten the screws on the mounting brackets.

Configuration

After mounting the INS in the vehicle it is essential to use the NAVconfig software to tell the INS what orientation it is in. Run the NAVconfig software and change the values on the Orientation page to match the installed orientation being used. Also check the position of the primary and secondary antenna values, since these may also be wrong in the new orientation.

Figure 6. NAVconfig Orientation page

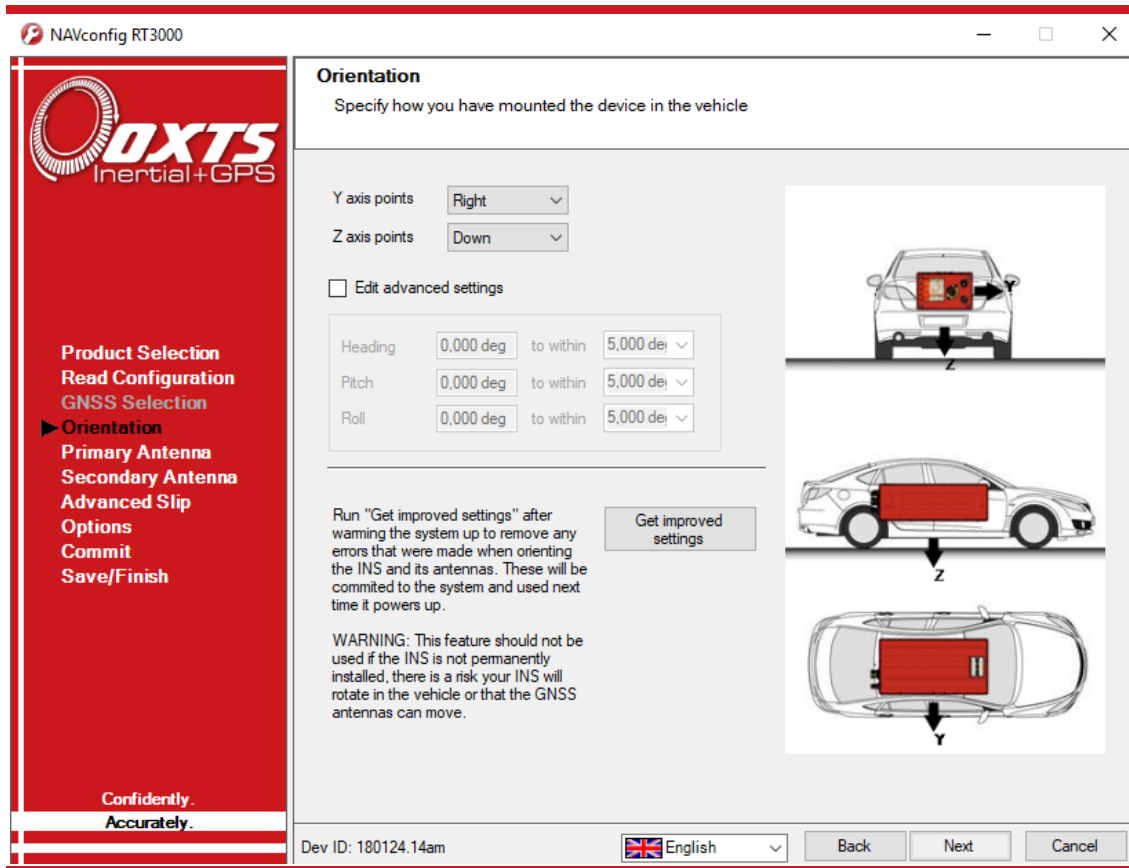

Revision history

Table 3. Revision history

Revision	Comments
041004	Initial Version
050503	Updates for RT-Strut Rev. 2
070312	Updated images
071122	Updates.
130611	Updated images, new mounting brackets, new software screenshot.
130917	Included Survey+. Replaced RT-Config with NAVconfig.
180316	Included RT1003. New logo update. Added safety notice to manual.
180322	Extended safety notice.
180510	Added clamp locking information