



OXTS

WayFinder Prime QUICK START GUIDE

Plug-and-play multi-sensor
localisation and mapping across
environments, from outdoor
sites to GNSS-denied spaces.

oxts.com

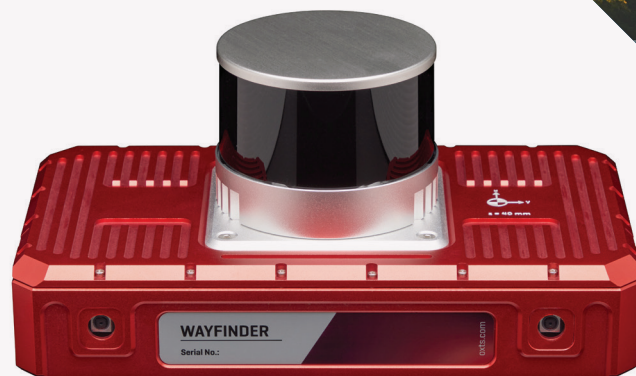

WELCOME TO WAYFINDER PRIME

This Quick Start Guide delivers clear, step-by-step instructions to get your WayFinder Prime up and running, so you can start navigating with pinpoint precision right away. For detailed information and advanced features, please refer to the full user manual.

What's in the box?

Component	Quantity
WayFinder Prime	x1
User cable (14C0238)	x1
Power extension cable (M12-M12)	x1
Hesai XT32M1X	x1
Hesai LiDAR cable (14C0240)	x1
LiDAR adapter plate (14M0279)	x1
LEMO caps	x3
USB stick	x1
Tape measure	x1
Declaration of Conformity	x1
Quick Start Guide	x1

Default network settings:

The WayFinder Prime network components adhere to the following default IP address configurations:

Device	Default IP address
INS	192.168.1.200
LiDAR	192.168.1.201
WayFinder PC	192.168.1.202

Ensure your PC's IPv4 address settings enable you to connect via Ethernet to communicate with the devices. The following settings are recommended:

IP range	192.168.1.xxx
Subnet mask	255.255.255.0

You will need:

- Laptop/PC with NAVsuite 3.14 (or later)
- Power cable with 4-way M12 female connector
- DC power supply, 10–28 V DC, ≥ 25 W output power
- Mounting bracket to secure WayFinder Prime to your platform/vehicle



INSTALL WAYFINDER



Step 1:

Mount the WayFinder Prime

Ensure the WayFinder Prime device is mounted rigidly to your platform/vehicle.



Step 2:

Position the antenna(s)

Mount the GNSS antenna(s) on the platform/vehicle with a clear view of the sky and suitable ground plane. They should be mounted away from any potential sources of interference, including the LiDAR.

If using dual antenna, a separation of at least 1 m is recommended. Ensure the cables exit the antennas in the same direction so they are facing the same way.



Step 3:

Connect the cables

Power supply → Power input
Laptop/PC → LEMO 1
LiDAR → LEMO 2
GNSS antennas → Primary and Secondary ports

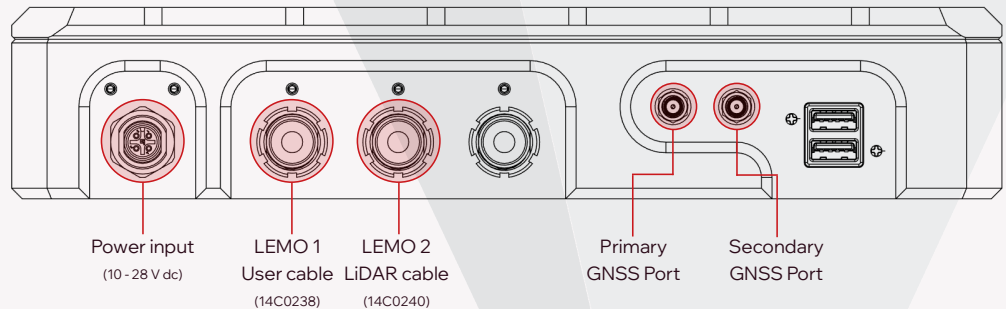

Step 4:

Supply power

Use a UPS or, if available, the platform/vehicle's power supply directly via the power input socket. The device may take up to one minute to boot.

CONFIGURE WAYFINDER PRIME

WayFinder Prime devices are set up using the NAVconfig app in NAVsuite.

They come preloaded with common settings, such as LiDAR lever arms. For first-time use, you'll need to set installation-specific parameters.

To begin, open NAVconfig and click **Modify configuration**.

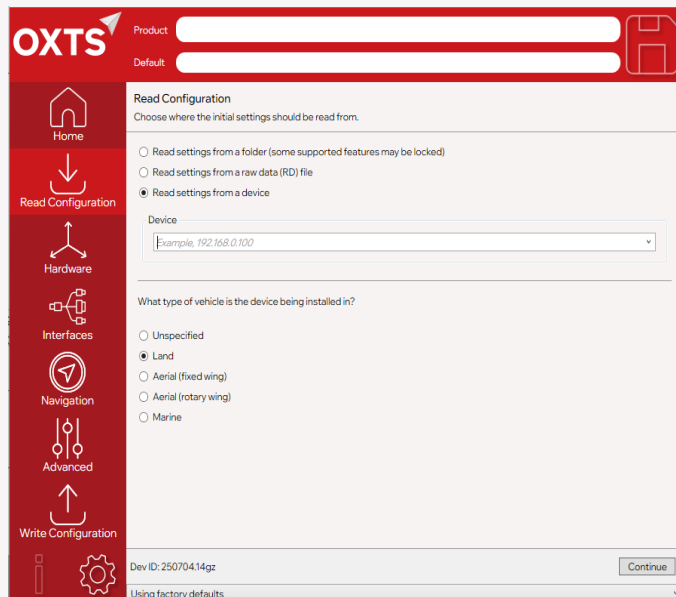
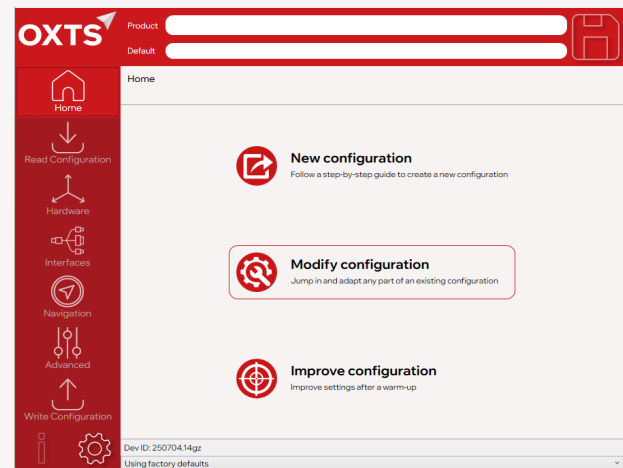

In the **Read Configuration** tab:

1. Select **Read settings from a device**.
2. Choose the IP address from the **Device** drop-down.
3. Specify the **type of platform/ vehicle** to which the WayFinder Prime is mounted.
4. Click **Continue** to edit the preloaded configuration.



Hardware



This section considers how the device is orientated on the platform/vehicle and where the antennas are located.

IMU Orientation

Set the Y and Z axis directions of the WayFinder Prime relative to your platform/vehicle.

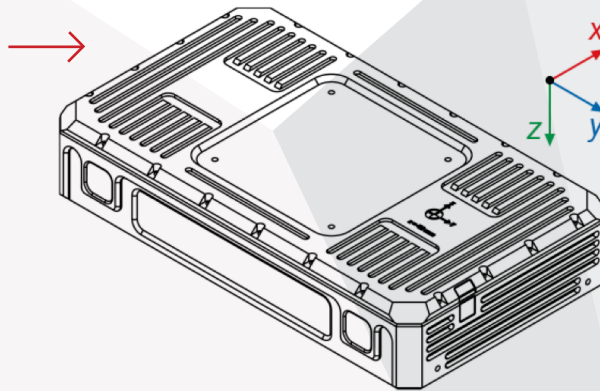

Primary/Secondary Antenna

Set the antenna position — ahead/behind, left/right, and above/below — relative to the WayFinder Prime measurement point.

Lateral/Vertical No-slip (optional)

For land-based vehicles with both steered and non-steered axles, set the centre point of each axle - ahead/behind and left/right - relative to the WayFinder Prime, and specify the WayFinder Prime's mounting height above the ground.

GNSS Differential Corrections (optional)

Select and configure your preferred source of GNSS differential corrections, or skip if using PPK with corrections applied during post-processing.

Navigation



This section considers the environment in which the device will be operating.

Initialisation

Check that the dynamic initialisation speed—preset to 5 m/s—is suitable for your platform/vehicle and adjust if needed. The WayFinder Prime will start outputting trajectory data once this speed is reached.

Write Configuration



When you're satisfied the settings accurately reflect your setup and intended operation, click 'Commit' on the Write Configuration page. The device will save the settings, reboot, and apply them on startup.





DATA COLLECTION

1. Power on - Connect WayFinder Prime to power and wait for INS power LED and INS processor LED to show red.

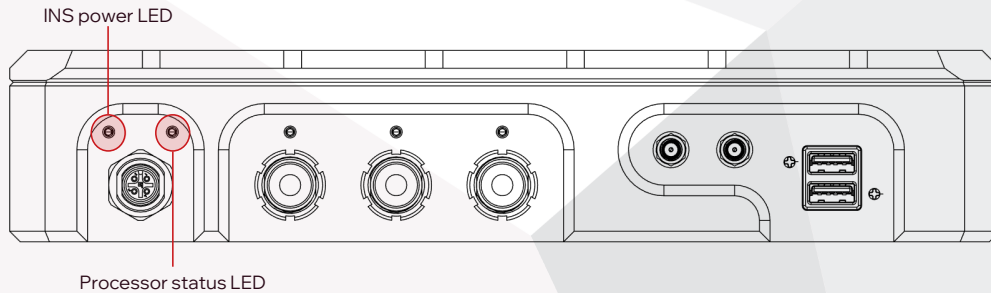

2. Initialise - Move in a straight line with good visibility of the sky, accelerating through your set initialisation speed. The default is 5 m/s (18 km/h or 11.2 mph).
3. Low-dynamics warm up - The WayFinder Prime only requires a very short period of representative, low dynamics movement to begin outputting data to specification.
4. Operate - Perform your mission.
5. De-initialise (Optional) - To boost post-processing accuracy, travel in a straight line above your initialisation speed before coming to a complete stop.

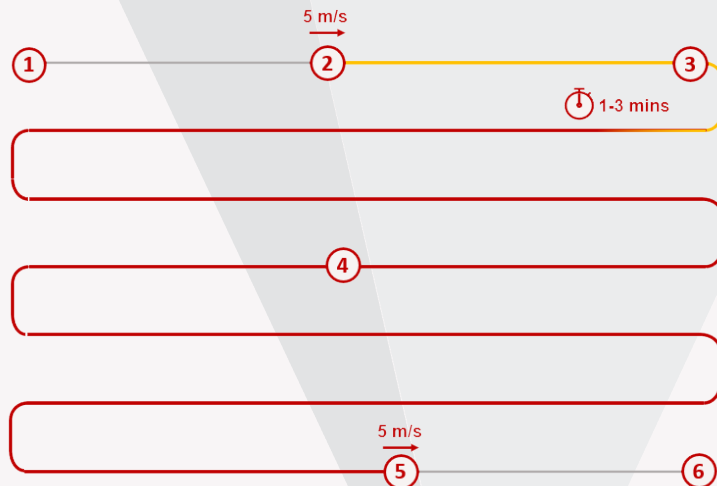

Visual representation of data collection process.

REAL-TIME MONITORING AND CONTROL

The WayFinder Prime hosts several web apps for monitoring and controlling the device via a browser.

Access the Homepage by entering the WayFinder PC's IP address—**192.168.1.202**—into your browser.

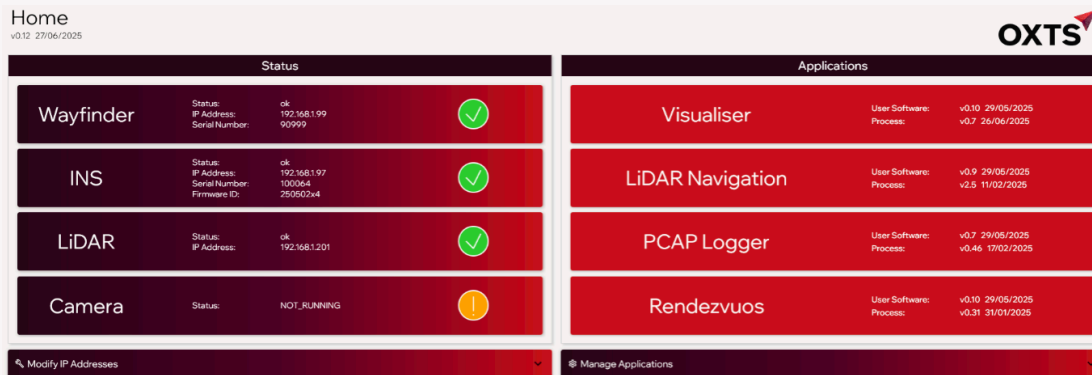

The homepage provides an overview of system status and simple access to other apps by clicking their tiles, which open in new tabs.

Visualiser

View navigation trajectory data from WayFinder Prime, send commands via the command bar, and see your position on an OpenStreetMap (internet required).

PCAP Logger

Logs data from LiDAR to the onboard SSD for post-processing use. Logging is disabled by default and can be turned on within the app.

LiDAR Navigation

The WayFinder Prime automatically uses LiDAR to aid with navigation. You can manually control and change settings in the LiDAR Navigation app if needed.

Rendezvuos

You can control the camera-based Zero Velocity Update (ZVU) from here. It starts automatically but can be manually controlled if needed.



RETRIEVING AND PROCESSING DATA

With your mission complete, retrieve your raw navigation data for post-processing and analysis as required by connecting to the device via FTP.

Using Windows File Explorer:

Type `FTP://192.168.1.200` in the address bar and hit Enter. Then copy the files you want to a local folder.

Using FileZilla:

Enter `192.168.1.200` in the “Host” box and connect. Copy the files you need to a local folder.

To retrieve any logged PCAP files, FTP using the WayFinder Prime PC IP - `192.168.1.202` - at `applications/pcap_logger_backend/data/`

Your navigation data is stored on the WayFinder Prime in a raw, unprocessed format with an .RD file extension. The great thing about this is that you can reprocess the data later using different configuration settings. So, if your settings were incorrect during the mission, you can simply update them and reprocess the data afterwards.



To do this, use the OXTS post-processing application called NAVsolve.

For full details on how to use NAVsolve, check out the **NAVsolve Manual** available for download on the OXTS support website.

BLANK FOR NOTES:





NEED FURTHER ASSISTANCE?

Visit the support website:
support.oxts.com

Get in touch if you can't find what you need:
support@oxts.com
+44(0)1869 814 251

OXTS 